

FACADE COULISSANTE – GAMME ALU – PROFIL Diamant

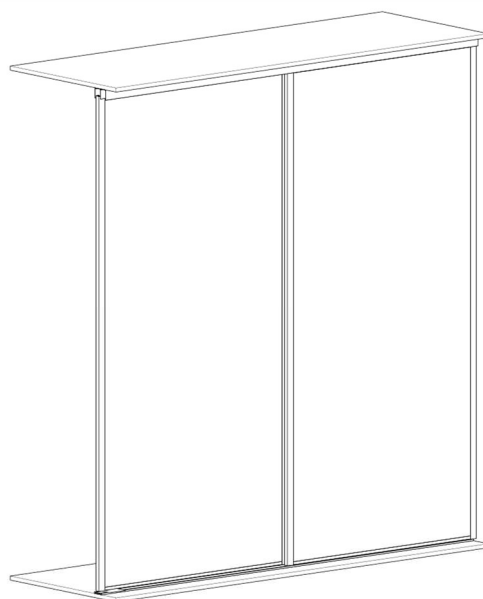

INFORMATIONS

Ce document est une notice regroupant les informations nécessaires aux différentes étapes de montage du produit **FACADE COULISSANTE – GAMME ALUMINIUM – PROFIL DIAMANT**

Vous pouvez retrouver cette notice sur notre site internet.

IMPORTANT

Nous vous conseillons d'être au minimum 2 personnes pour le montage de nos produits.

Aucune visserie n'est fournie pour la fixation au mur, au sol, ou au plafond. Il vous faudra vous adapter à votre support.

CONSEIL D'ENTRETIEN

Panneaux mélaminés mat ou structuré :

A l'aide d'une éponge humide savonneuse. Rincer à l'eau claire après le nettoyage, puis sécher correctement avec un chiffon propre.

Si l'eau ne suffit pas, vous pouvez utiliser du produit nettoyant pour vitres.



Ne pas utiliser de produits abrasifs, ni de produits à base forte et acide fort.

ECO-ORGANISMES

 | N° REGISTRE FR019580_03UNYT



 | N° REGISTRE FR019580_103YUI
N° REGISTRE FR019580_04FIWL



OUTILS

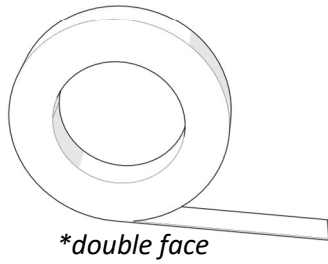
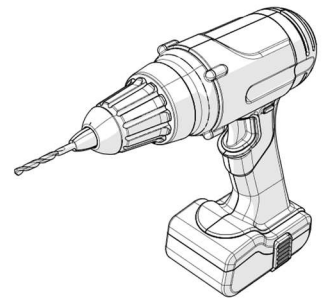
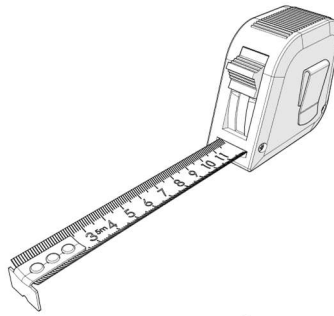
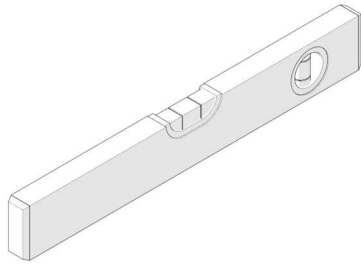
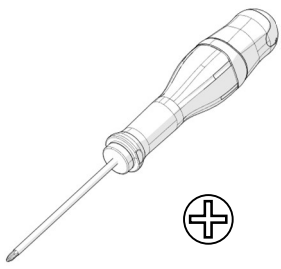

QUINCAILLERIES

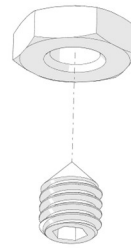
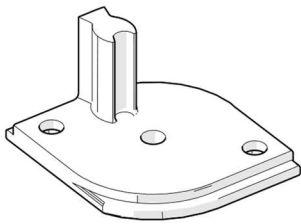

FIXATIONS

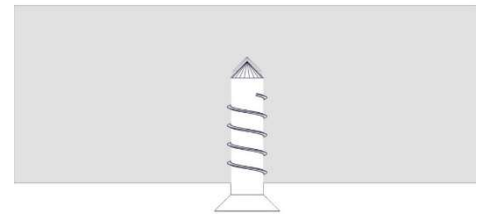
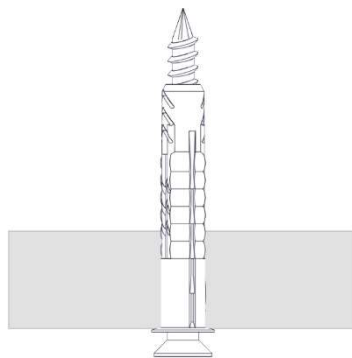
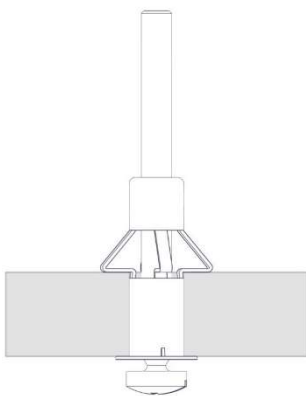

Les fixations ne sont pas fournies

Le choix de la fixation vis + cheville doit être adapté au sol et au plafond

1. Installation des déclencheurs

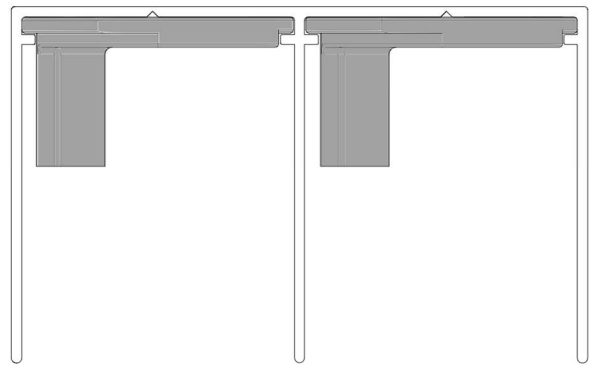
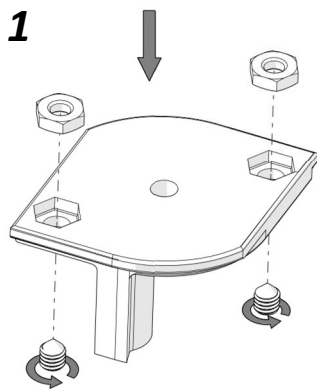

AVANT



DISPOSITION DES DECLENCHEURS :

Voir feuille en annexe
(dernière page de la notice)

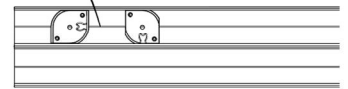
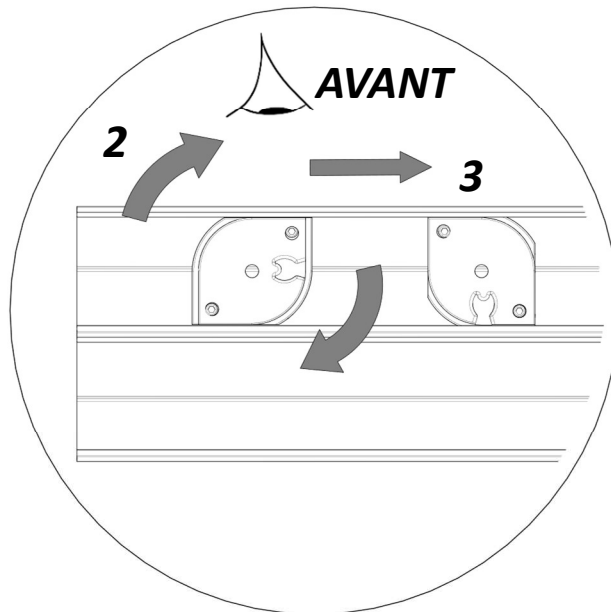

2. Fixation du rail haut

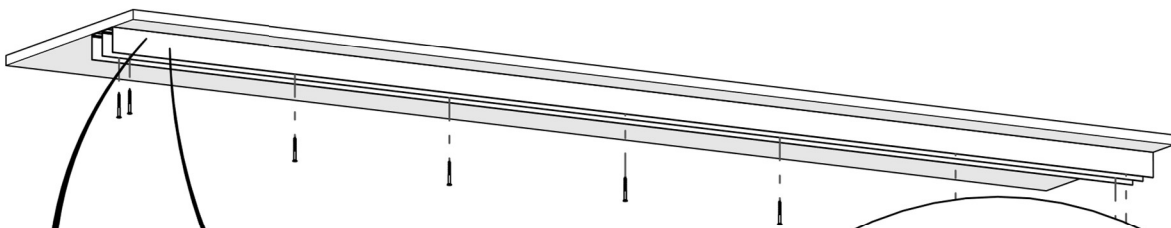

1-Perçage

50mm 400mm à 500mm en quinconces

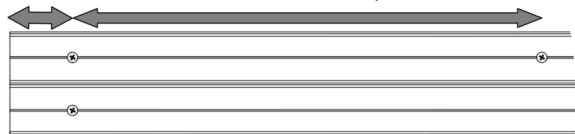

2-Vissage

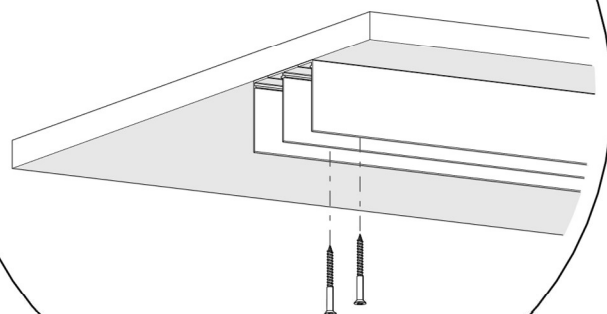

3. Positionnement du rail bas

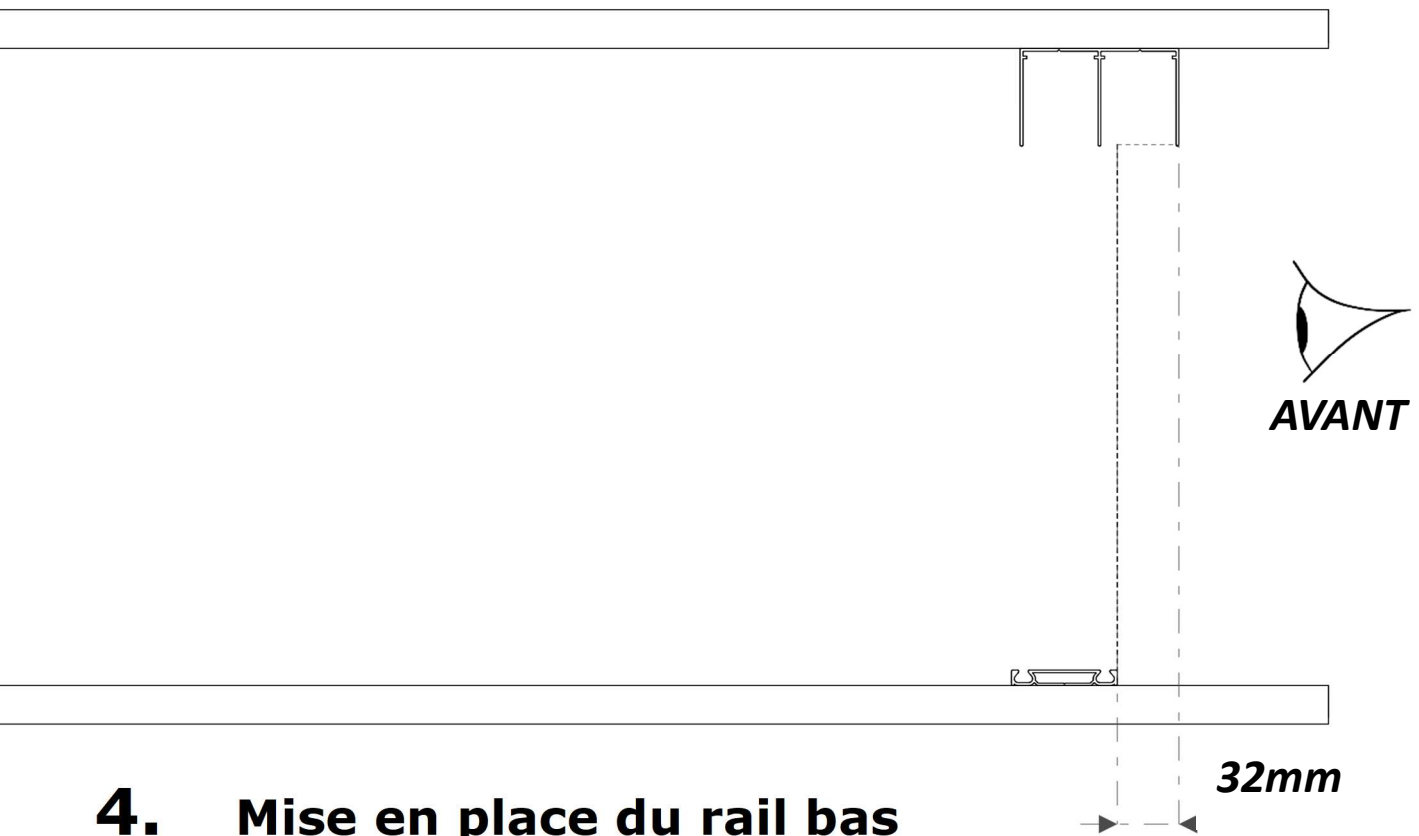

4. Mise en place du rail bas

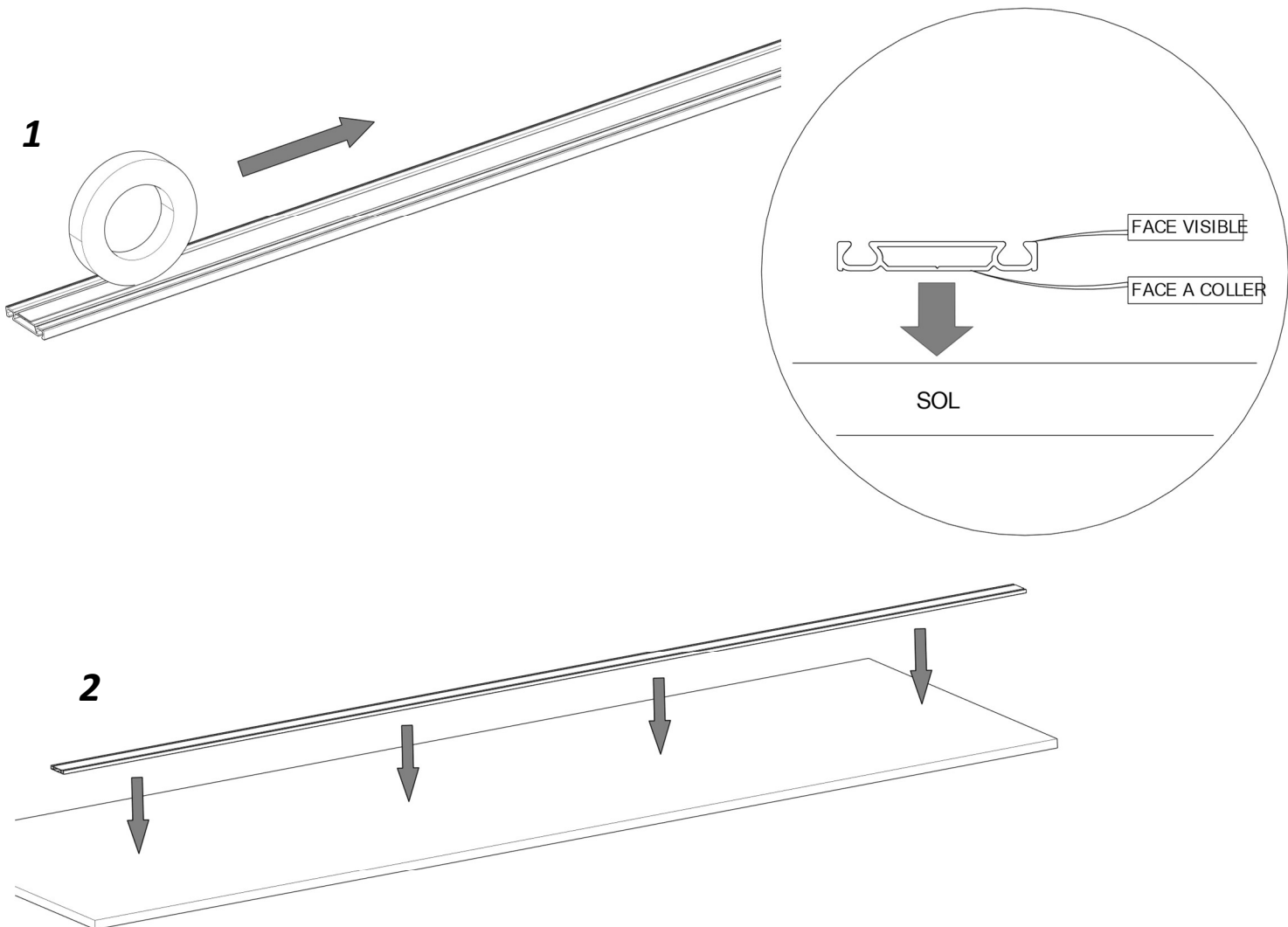

5. Enclenchement des amortisseurs

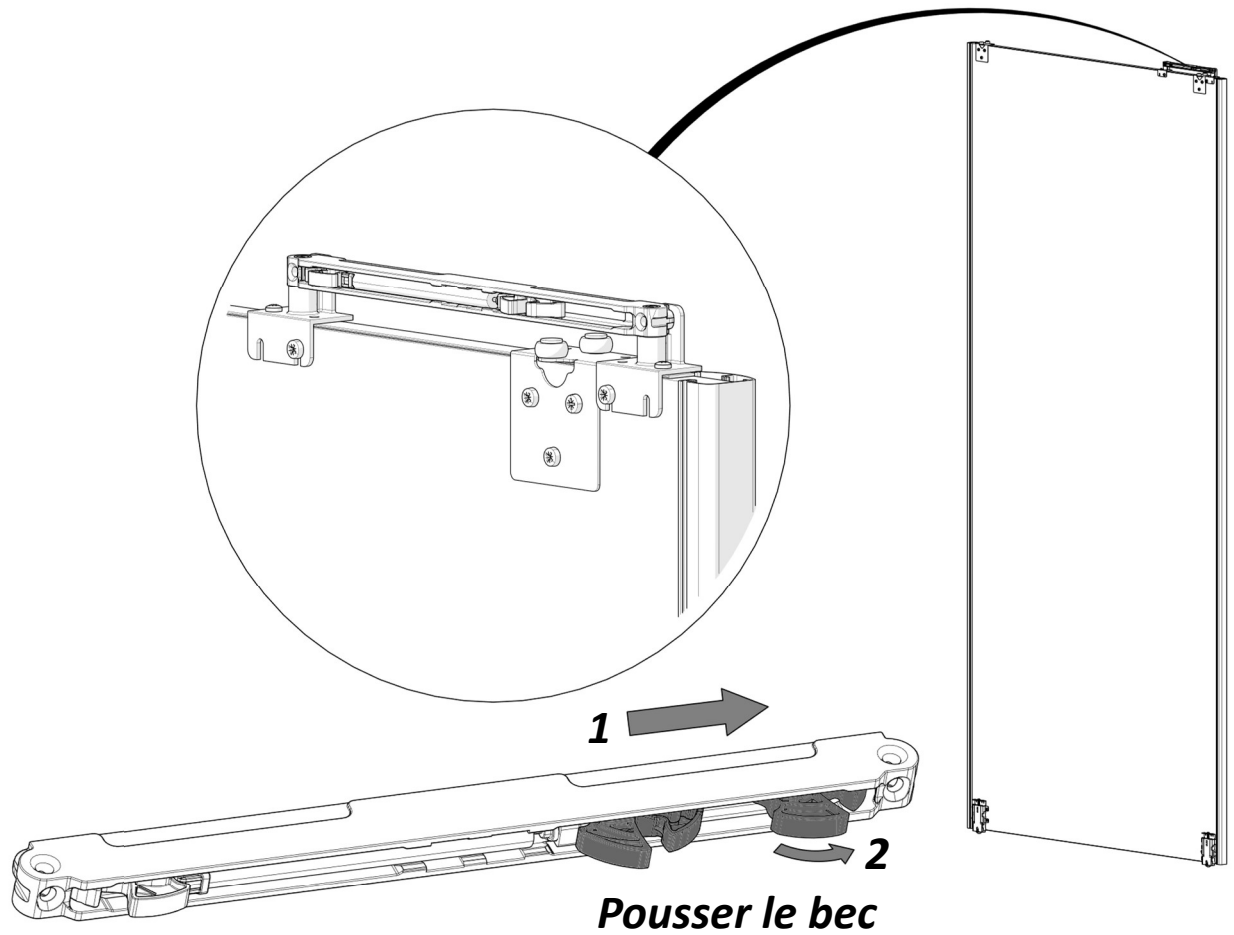

6. Installation du vantail arrière

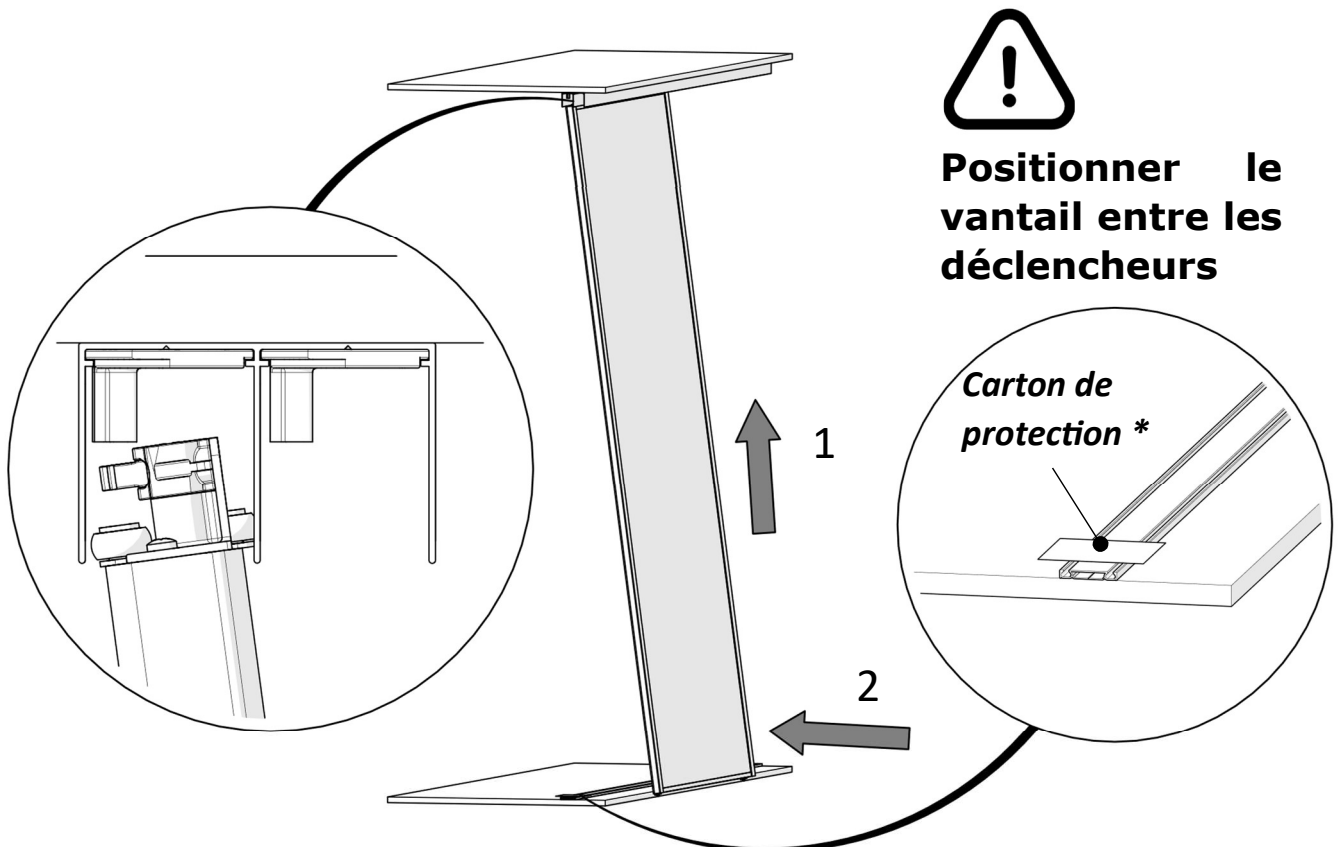

7. Dévissage des roulettes

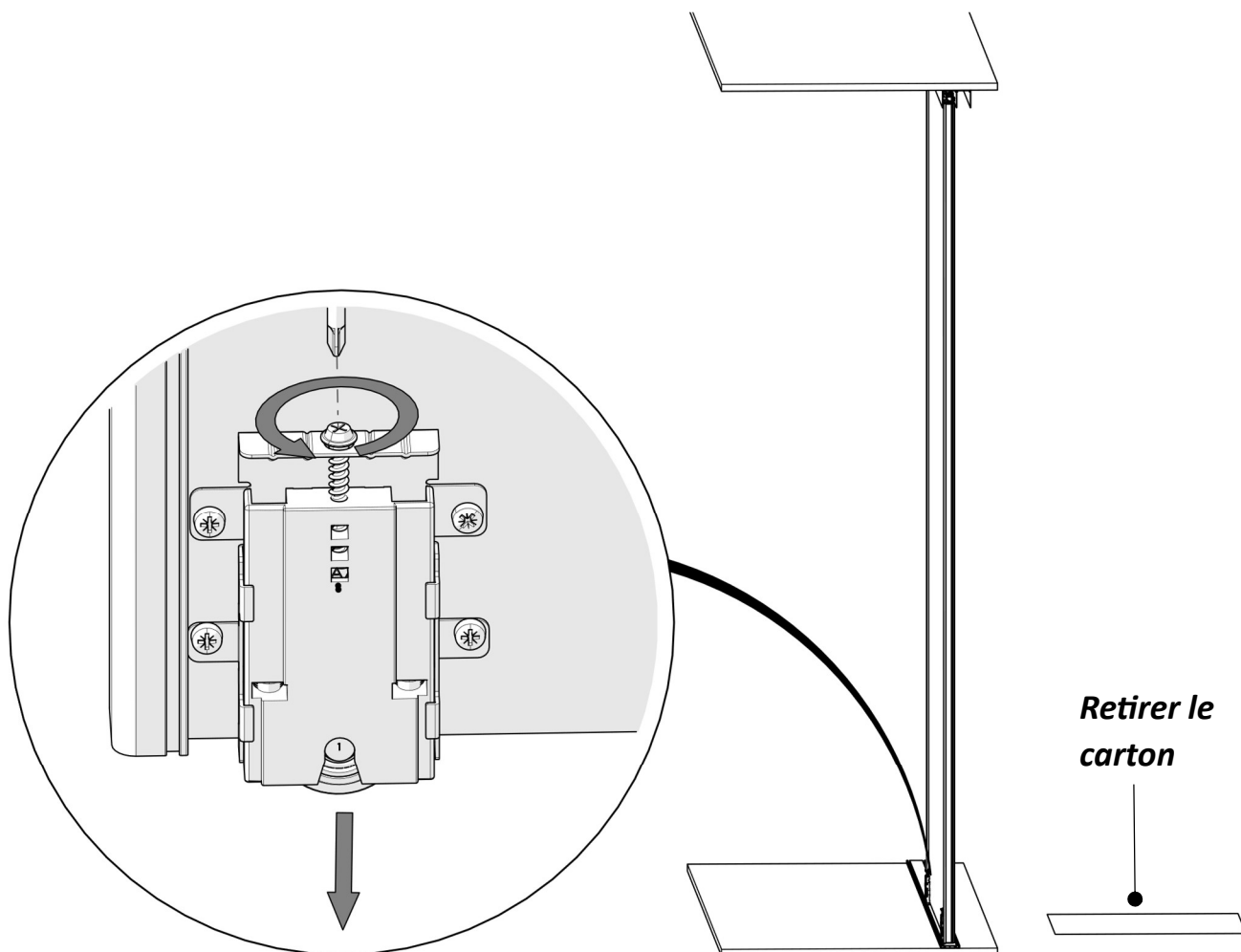

8. Installation du vantail avant

Répéter les opérations 5 à 7

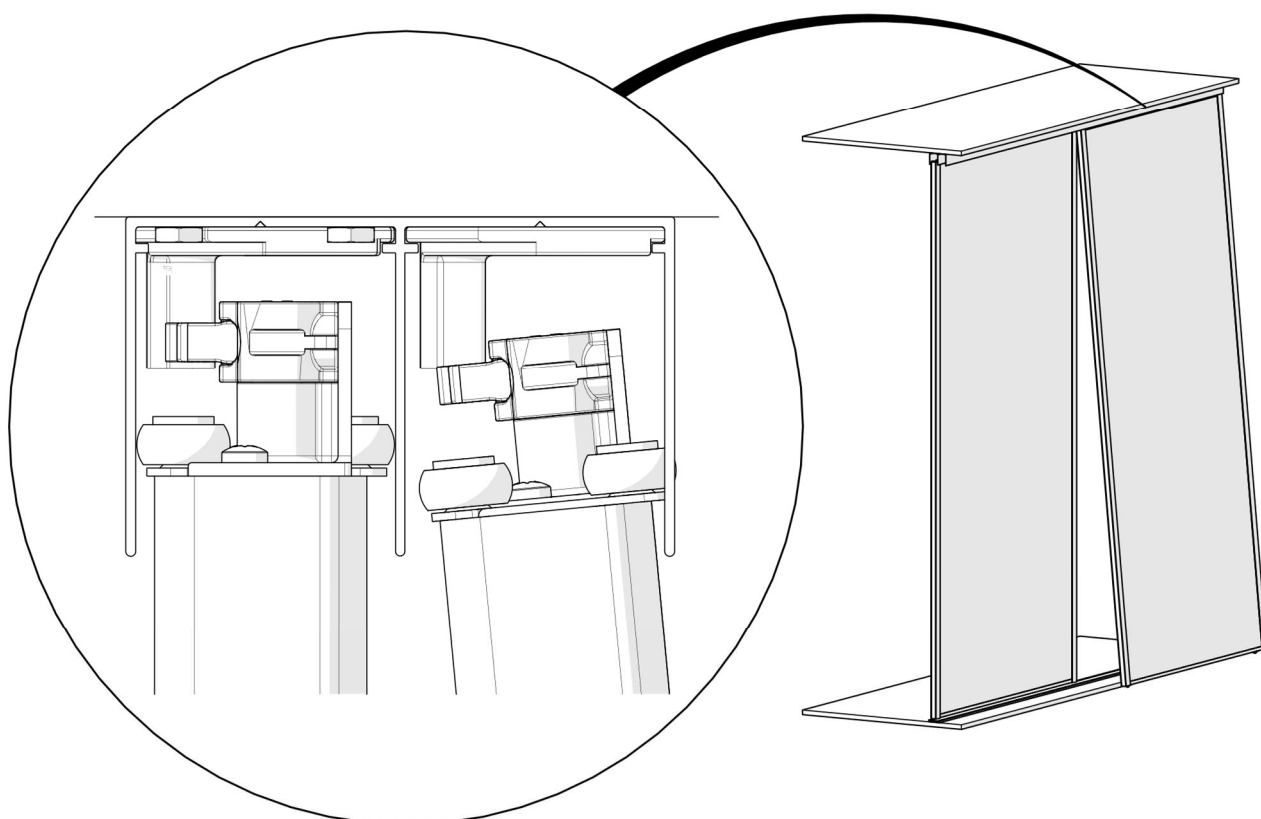

9. Réglage de l'aplomb des vantaux

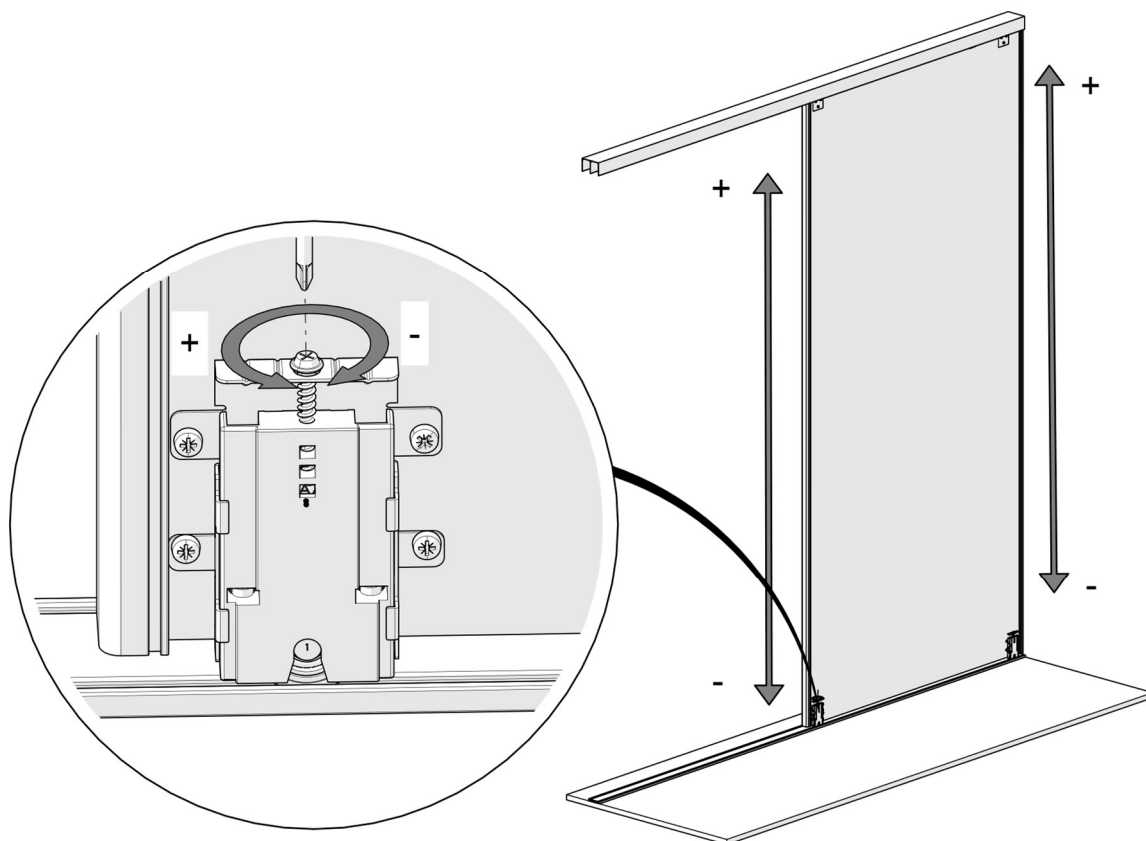

10. Ajustement et verrouillage des déclencheurs

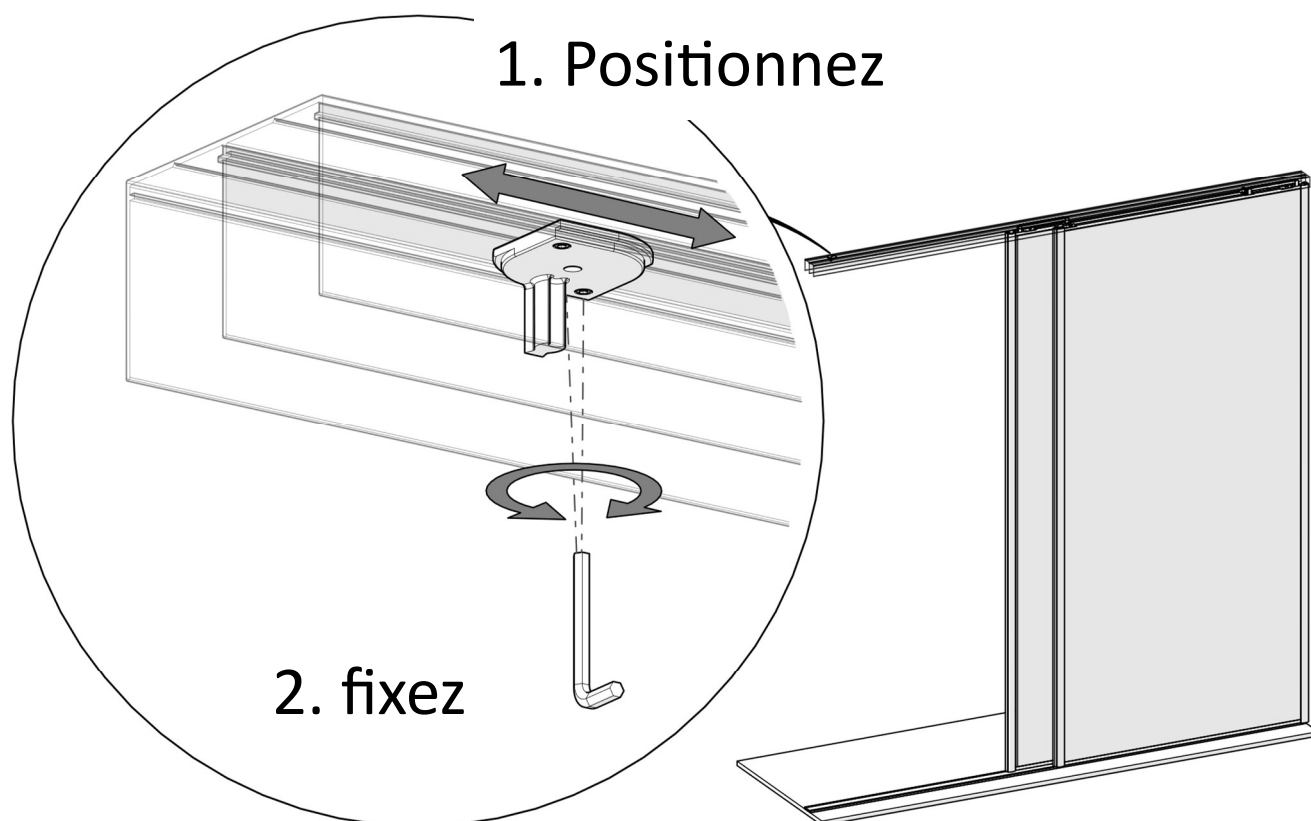

ANNEXE

FACADE COULISSANTE RAIL EXTRA PLAT (Profil diamant)

DISPOSITION DOIGTS D'ACCROCHAGE

2 Vantaux - 4 doigts d'accrochage

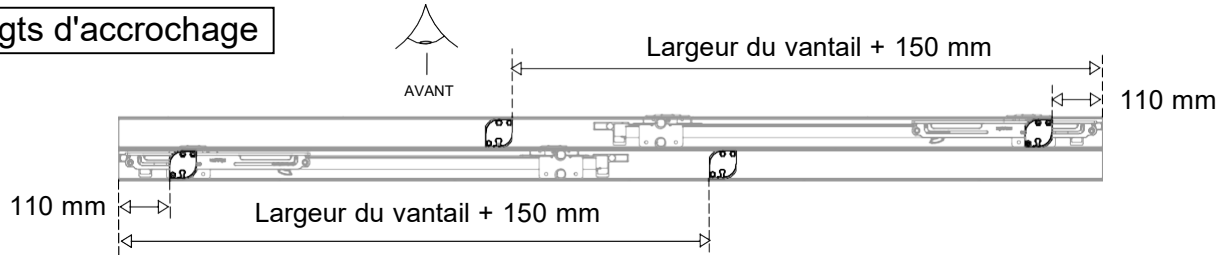

3 Vantaux - 6 doigts d'accrochage

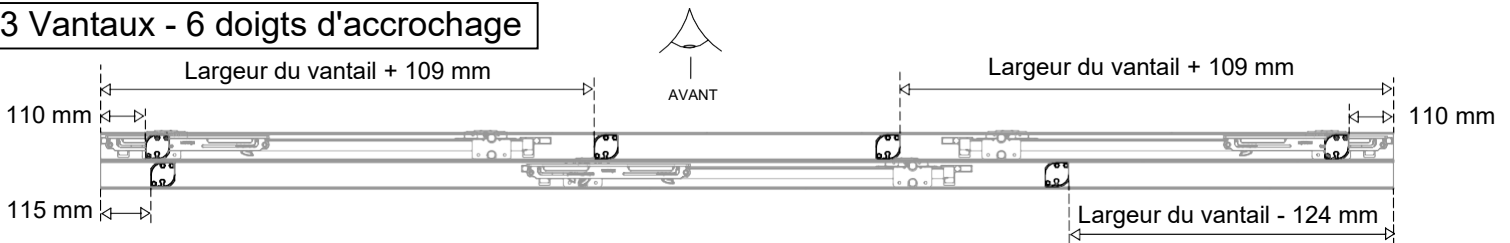

4 Vantaux - 8 doigts d'accrochage

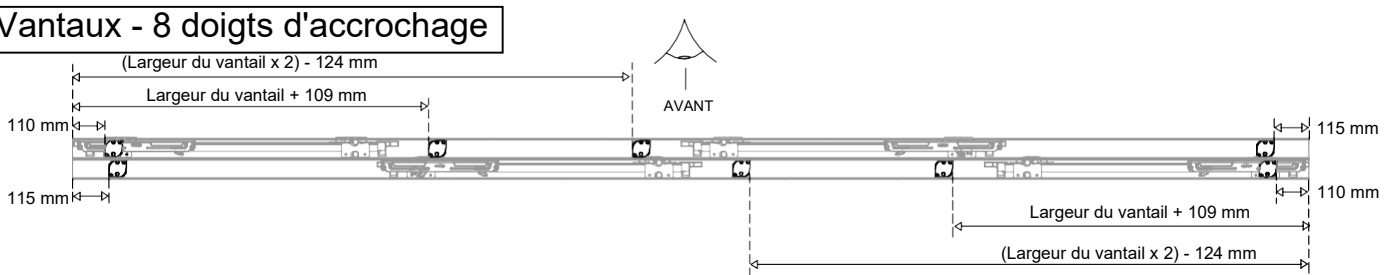

5 Vantaux - 9 doigts d'accrochage

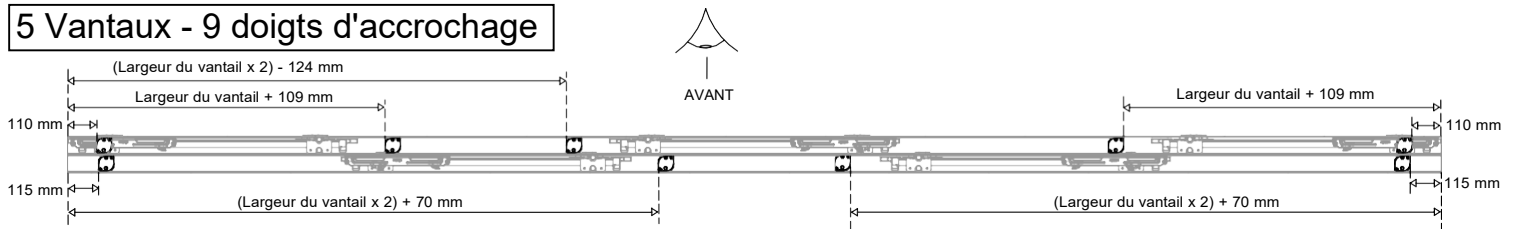

6 Vantaux - 10 doigts d'accrochage

